



# Hob Mounted Pre-Rinse Unit

14.1

## Product Code: T-F2110-WB

Durable and well constructed these pre-rinse units are the ideal solution for high use commercial applications.

Including long lasting swivelling seat discs, and internal check valve to avoid cross contamination.

## Features and Benefits

- Swivelling seat disc
- Internal Spring loaded check valve
- 36" 3-ply fiber reinforced rubber hose (stainless steel external jacket)
- Ultra spray rinse valve
- Adjustable Wall Bracket
- WELS approved Lic#0308

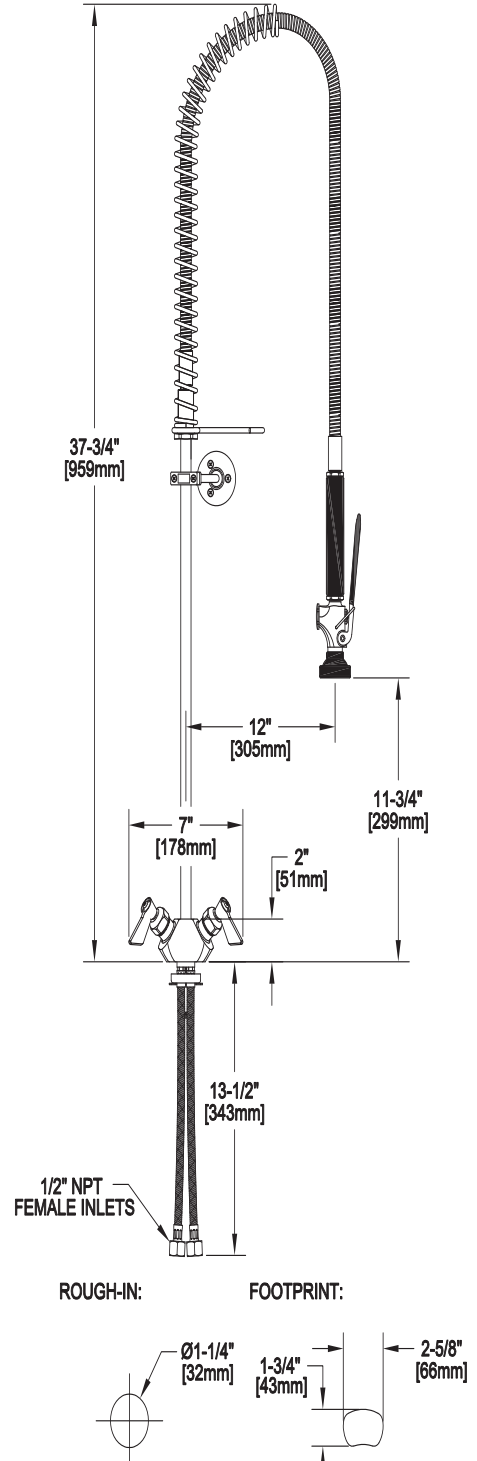

**"another great idea"**

6 / 24 Wellington St  
Riverstone NSW 2765

P. 02 9627 6111  
F. 02 9627 3111

info@3monkeez.com.au  
www.3monkeez.com.au

Details accurate at time of print. It is possible that some details may change without notice. Whilst all care has been taken in compiling this information designs & dimensions shown are indicative only and should not be relied upon without prior approval.