



Hob Mounted Pre Rinse Unit with 300mm Pot Filler

14.2

Product Code: T-F34193

Durable and well constructed these pre-rinse units are the ideal solution for high use commercial applications.

Including long lasting swivelling seat discs and internal check valve to avoid cross contamination.

Features and Benefits

- Swivelling seat disc
- Internal spring loaded check valve
- Adjustable Wall Bracket
- 36" 3-ply fibre reinforced rubber hose (stainless steel external jacket)
- Ultra Spray
- WELS Approved Lic#0308

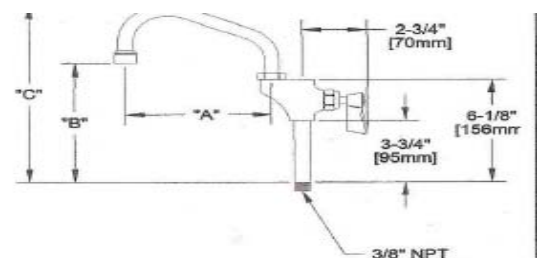
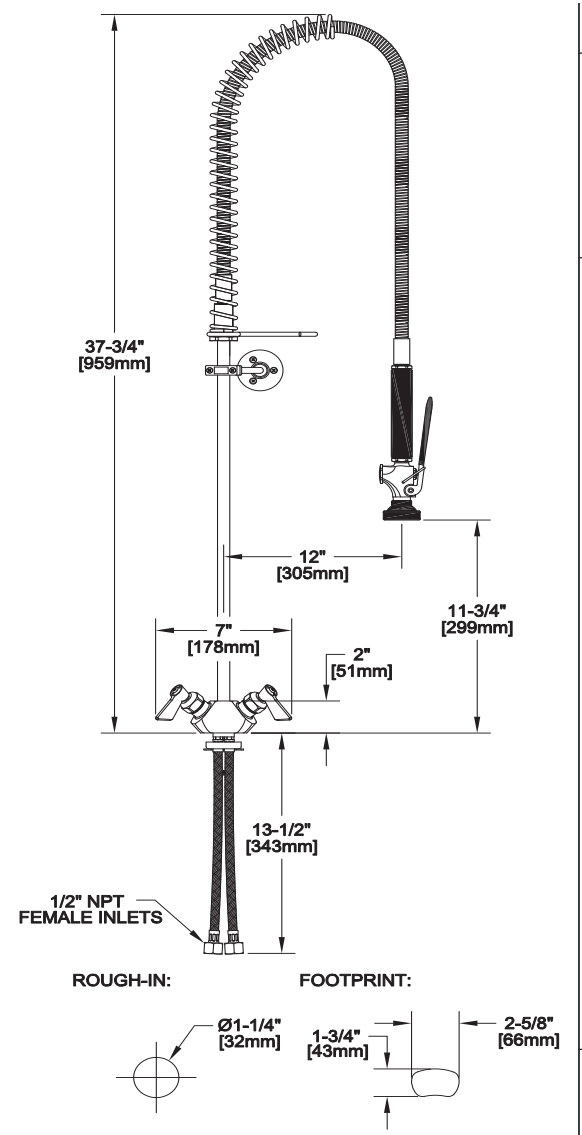

"another great idea"

6 / 24 Wellington St
Riverstone NSW 2765

P. 02 9627 6111
F. 02 9627 3111

info@3monkeez.com.au
www.3monkeez.com.au

Details accurate at time of print. It is possible that some details may change without notice. Whilst all care has been taken in compiling this information designs & dimensions shown are indicative only and should not be relied upon without prior approval.