

Top

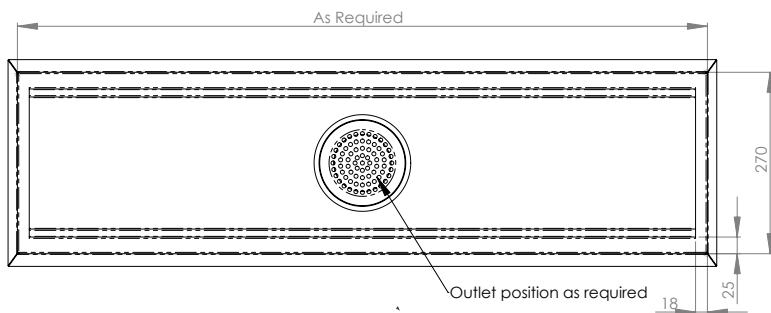

Front

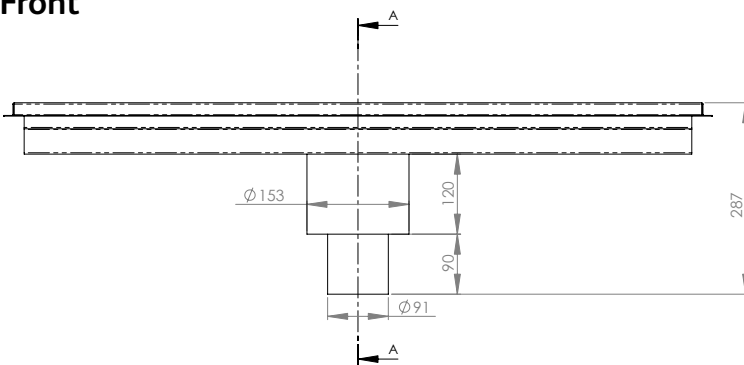

Cross-section A-A

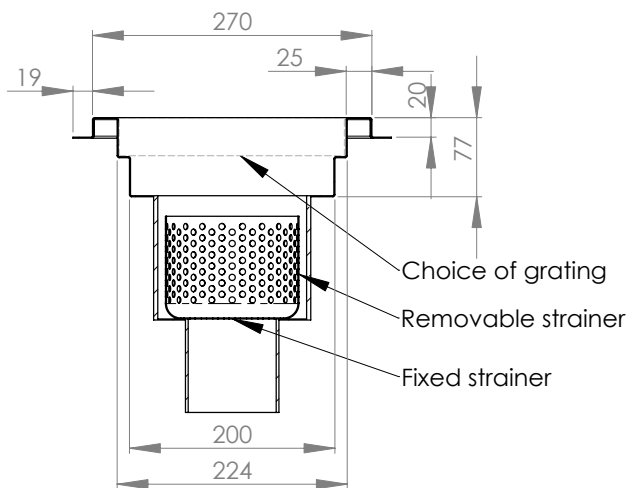

Product Code:
M-FT-1

This flexible floor trough is typically used for commercial applications. It can be manufactured to any required length and width. Additionally, it is adaptable to a range of grating options. The size and position of the outlet can be manufactured to the customer's requirements.

Features and Benefits:

- Manufactured to required length and width using a choice of either 304 or 316 grade stainless steel
- Optional fixed secondary strainer and removable strainer basket
- Size of outlet and position manufactured to the customer's requirements
- Typically used for commercial applications
- It can be installed with wedge wire or square bar grating
- Loading as required



Unit 6, 24 Wellington Street, Riverstone NSW 2765
Tel: 02 9627 6111 Fax: 02 9627 3111
sales@3monkeez.com.au
www.3monkeez.com.au

Details accurate at time of print. It is possible that some details may change without notice. Whilst all care has been taken in compiling this information, designs & dimensions shown are indicative only and should not be relied upon without prior approval.

